



*Healthy gentle rolling.*

# Medical equipment castors

## The innovation: 399

High grade, centrally lockable bed castor with new integrated wheel lock. Various colours possible, hygiene-friendly, corrosion-free. Suitable for cleaning in disinfection cabins. Aluminium die-cast housing. Sealed precision ball bearings in the fork head, brake contour adapted to wheel, maintenance-free. 150 kg load capacity.

Unique design: *winner of red dot design award!*

Sometimes it's a matter of seconds – the right medication, the appropriate team, and the necessary luck. Fine, at times like this you need the reassurance that the castors from RHOMBUS are dependable. We deliver our promises: quiet operation, load-bearing capacity, safety and long product life.

# 390q

Swivel castor with central brake

# 390r

Swivel castor with directional brake

### Technical description

- Sheet steel metal
- Zinc passivated
- Double ball bearing in swivel head
- Protected from dust and water ingress by plastic sealing ring
- Integrated selection mechanism with total lock "q" and directional locking "r"
- Selection mechanism continually greased
- Device to permit adjustment of the braking effect (without removing the castor or wheel)
- Also available with other wheel variants (see on page 127+128)

### Areas of application

- Care beds
- Hospital beds
- Intensive care beds
- OP beds

Guideline for finding the correct structure of attachment, sockets for round and square tubes, as well as foot and transmission lever, see on pages 81-83



<b>390q 390r</b>	29K	080r	Z2351	80	30	113	44	100	
<b>390q 390r</b>	29K	100r	Z2351	100	30	133	42	100	
<b>390q 390r</b>	29K	125r	Z2351	125	32	158	44	100	
<b>390q 390r</b>	29K	150r	Z2351	150	32	184	51	120	
<b>390q 390r</b>	29K	200r	Z2351	200	32	237	61	120	



<b>390q 390r</b>	29K	080r	Z985	80	30	113	44	100	
<b>390q 390r</b>	29K	100r	Z985	100	30	133	42	100	
<b>390q 390r</b>	29K	125r	Z985	125	32	158	44	100	
<b>390q 390r</b>	29K	150r	Z985	150	32	184	51	120	
<b>390q 390r</b>	29K	200r	Z985	200	32	237	61	120	



<b>390q 390r</b>	32C	080b	Z2351	80	30	113	44	80	
<b>390q 390r</b>	32C	100b	Z2351	100	32	133	42	80	
<b>390q 390r</b>	32C	125b	Z2351	125	32	158	44	100	
<b>390q 390r</b>	32C	150b	Z2351	150	32	184	51	110	
<b>390q 390r</b>	32C	200b	Z2351	200	32	237	61	120	



<b>390q 390r</b>	32C	080b	Z985	80	30	113	44	80	
<b>390q 390r</b>	32C	100b	Z985	100	32	133	42	80	
<b>390q 390r</b>	32C	125b	Z985	125	32	158	44	100	
<b>390q 390r</b>	32C	150b	Z985	150	32	184	51	110	
<b>390q 390r</b>	32C	200b	Z985	200	32	237	61	120	

# 390+q Swivel castor with central brake

# 390+r Swivel castor with directional brake

*Technical description*







- Sheet steel metal
- Zinc passivated
- Double ball bearing in swivel head
- Up-to-date design with high-quality plastic cover
- Suitable for cleaning in disinfecting cubicle
- Protected from dust and water
- Integrated selection mechanism with total lock "q" and directional locking "r"
- Selection mechanism continually greased
- Also available with other wheel variants (see on page 127)

*Areas of application*







- Care beds
- Hospital beds
- Intensive care beds
- OP beds

Guideline for finding the correct structure of attachment, sockets for round and square tubes, as well as foot and transmission lever, see on pages 81-83









										
<b>390q</b>	<b>390r</b>	29K	100r	Z2351 C	100	30	133	42	RAL 9010	100
<b>390q</b>	<b>390r</b>	29K	125r	Z2351 C	125	32	158	44	RAL 9010	100
<b>390q</b>	<b>390r</b>	29K	150r	Z2351 C	150	32	184	51	RAL 9010	120
<b>390q</b>	<b>390r</b>	29K	200r	Z2351 C	200	32	237	61	RAL 9010	120









										
<b>390q</b>	<b>390r</b>	29K	100r	Z985 C	100	30	133	42	RAL 9010	100
<b>390q</b>	<b>390r</b>	29K	125r	Z985 C	125	32	158	44	RAL 9010	100
<b>390q</b>	<b>390r</b>	29K	150r	Z985 C	150	32	184	51	RAL 9010	120
<b>390q</b>	<b>390r</b>	29K	200r	Z985 C	200	32	237	61	RAL 9010	120



										
<b>390q</b>	<b>390r</b>	29K	100r	Z2351 CA	100	30	133	42	metallic	100
<b>390q</b>	<b>390r</b>	29K	125r	Z2351 CA	125	32	158	44	metallic	100
<b>390q</b>	<b>390r</b>	29K	150r	Z2351 CA	150	32	184	51	metallic	120
<b>390q</b>	<b>390r</b>	29K	200r	Z2351 CA	200	32	237	61	metallic	120



										
<b>390q</b>	<b>390r</b>	29K	100r	Z985 CA	100	30	133	42	metallic	100
<b>390q</b>	<b>390r</b>	29K	125r	Z985 CA	125	32	158	44	metallic	100
<b>390q</b>	<b>390r</b>	29K	150r	Z985 CA	150	32	184	51	metallic	120
<b>390q</b>	<b>390r</b>	29K	200r	Z985 CA	200	32	237	61	metallic	120

Technical description

- Sheet steel metal
- Zinc passivated
- Double ball bearing in swivel head
- Up-to-date design with high-quality plastic cover
- Suitable for cleaning in disinfecting cubicle
- Protected from dust and water
- Integrated selection mechanism with total lock "q" and directional locking "r"
- Selection mechanism continually greased
- Also available with other wheel variants (see on page 128)

Areas of application

- Care beds
- Hospital beds
- Intensive care beds
- OP beds

Guideline for finding the correct structure of attachment, sockets for round and square tubes, as well as foot and transmission lever, see on pages 81-83



<b>390q</b>	<b>390r</b>	32C	125b	Z2351 C	125	32	158	44	RAL 9010	100
<b>390q</b>	<b>390r</b>	32C	150b	Z2351 C	150	32	184	51	RAL 9010	110
<b>390q</b>	<b>390r</b>	32C	200b	Z2351 C	200	32	237	61	RAL 9010	120



<b>390q</b>	<b>390r</b>	32C	125b	Z985 C	125	32	158	44	RAL 9010	100
<b>390q</b>	<b>390r</b>	32C	150b	Z985 C	150	32	184	51	RAL 9010	110
<b>390q</b>	<b>390r</b>	32C	200b	Z985 C	200	32	237	61	RAL 9010	120



<b>390q</b>	<b>390r</b>	32C	125b	Z2351 CA	125	32	158	44	metallic	100
<b>390q</b>	<b>390r</b>	32C	150b	Z2351 CA	150	32	184	51	metallic	110
<b>390q</b>	<b>390r</b>	32C	200b	Z2351 CA	200	32	237	61	metallic	120



<b>390q</b>	<b>390r</b>	32C	125b	Z985 CA	125	32	158	44	metallic	100
<b>390q</b>	<b>390r</b>	32C	150b	Z985 CA	150	32	184	51	metallic	110
<b>390q</b>	<b>390r</b>	32C	200b	Z985 CA	200	32	237	61	metallic	120

# 391q

Swivel castor with central brake

# 391r

Swivel castor with directional brake

### Technical description

- Sheet steel metal
- Zinc passivated or chrome-plated
- Suitable for cleaning in disinfecting cubicle
- Integrated selection mechanism with total locking brake “q” and directional lock brake “r”
- Selection mechanism continually greased
- Device to permit adjustment of the braking effect (without removing the castor or wheel)
- Also available with other wheel variants (see on page 127+128)







### Areas of application

- Care beds
- Hospital beds
- Intensive care beds
- OP beds







Precision ball bearings in the fork head

Guideline for finding the correct structure of attachment, sockets for round and square tubes, as well as foot and transmission lever, see on pages 81-83









									
<b>391q 391r</b>	29K	100r	Z2351	100	30	139	42	100	
<b>391q 391r</b>	29K	125r	Z2351	125	32	164	44	100	
<b>391q 391r</b>	29K	150r	Z2351	150	32	191	51	120	
<b>391q 391r</b>	29K	200r	Z2351	200	32	243	61	120	









									
<b>391q 391r</b>	29K	100r	Z985	100	30	139	42	100	
<b>391q 391r</b>	29K	125r	Z985	125	32	164	44	100	
<b>391q 391r</b>	29K	150r	Z985	150	32	191	51	120	
<b>391q 391r</b>	29K	200r	Z985	200	32	243	61	120	



									
<b>391q 391r</b>	32C	100b	Z2351	100	32	139	42	80	
<b>391q 391r</b>	32C	125b	Z2351	125	32	164	44	100	
<b>391q 391r</b>	32C	150b	Z2351	150	32	191	51	120	
<b>391q 391r</b>	32C	200b	Z2351	200	32	243	61	120	



									
<b>391q 391r</b>	32C	100b	Z985	100	32	139	42	80	
<b>391q 391r</b>	32C	125b	Z985	125	32	164	44	100	
<b>391q 391r</b>	32C	150b	Z985	150	32	191	51	120	
<b>391q 391r</b>	32C	200b	Z985	200	32	243	61	120	

# 380 q Swivel castor with central brake

# 380 r Swivel castor with directional brake

### Technical description

- Plastic housing of polyamide white 9010 or metallic
- Precision ball bearings in the fork head
- Suitable for cleaning in disinfecting cubicles
- Modern design
- Smooth selection function
- Integrated selection mechanism with total locking brake "q" and direction locking brake "r"
- Selection mechanism continually greased
- For technical description of wheels see page 127

### Areas of application

- Care beds
- Hospital beds
- Intensive care beds
- OP beds

Guideline for finding the correct structure of attachment, sockets for round and square tubes, as well as foot and transmission lever, see on pages 81-83



<b>380q 380r</b>	29K 125v	K2351	125	32	161	41,2	RAL 9010	100		
<b>380q 380r</b>	29K 150v	K2351	150	32	185	50	RAL 9010	120		



<b>380q 380r</b>	29K 125v	K985	125	32	161	41,2	RAL 9010	100		
<b>380q 380r</b>	29K 150v	K985	150	32	185	50	RAL 9010	120		



<b>380q 380r</b>	29K 125v	K2351 A	125	32	161	41,2	metallic	100		
<b>380q 380r</b>	29K 150v	K2351 A	150	32	185	50	metallic	120		



<b>380q 380r</b>	29K 125v	K985 A	125	32	161	41,2	metallic	100		
<b>380q 380r</b>	29K 150v	K985 A	150	32	185	50	metallic	120		



reddot design award

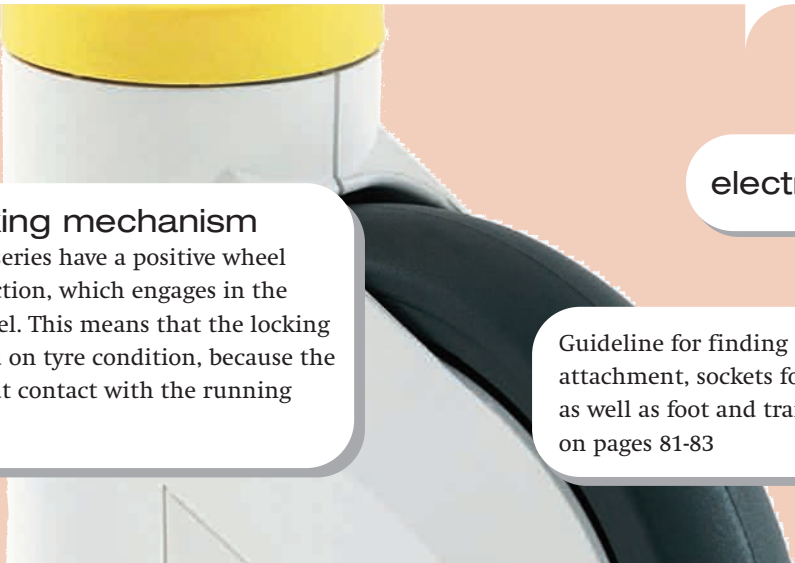

**Innovative locking mechanism**

The castors of the 380 series have a positive wheel lock, not reliant on friction, which engages in the central web of the wheel. This means that the locking action does not depend on tyre condition, because the castor is braked without contact with the running surface of the tyre.

electrically conductive!

Guideline for finding the correct structure of attachment, sockets for round and square tubes, as well as foot and transmission lever, see on pages 81-83



<b>380q 380r</b>	29K 125y	K2351	125	32	161	41,2	RAL 9010	100		
<b>380q 380r</b>	29K 150y	K2351	150	32	185	50	RAL 9010	120		



<b>380q 380r</b>	29K 125y	K985	125	32	161	41,2	RAL 9010	100		
<b>380q 380r</b>	29K 150y	K985	150	32	185	50	RAL 9010	120		



<b>380q 380r</b>	29K 125y	K2351 A	125	32	161	41,2	metallic	100		
<b>380q 380r</b>	29K 150y	K2351 A	150	32	185	50	metallic	120		



<b>380q 380r</b>	29K 125y	K985 A	125	32	161	41,2	metallic	100		
<b>380q 380r</b>	29K 150y	K985 A	150	32	185	50	metallic	120		

# 382q

Swivel castor with central brake

# 382r

Swivel castor with directional brake

### Technical description

- Plastic housing of polyamide white RAL 9016 or signal grey RAL 7004
- Precision ball bearings in the fork head
- Suitable for cleaning in disinfecting cubicles
- Smooth selection function
- Integrated selection mechanism with total locking brake "q" and direction locking brake "r"
- Selection mechanism continually greased

### Areas of application

- Care beds
- Hospital beds
- OP beds

Guideline for finding the correct structure of attachment, foot and transmission lever, see on pages 81-83



<b>382q</b>	<b>382r</b>	40K	125v	K235W	125	60	165	30,7	RAL 9016	100
<b>382q</b>	<b>382r</b>	40K	150v	K235W	150	60	190	40	RAL 9016	120



<b>382q</b>	<b>382r</b>	40K	125v	K985W	125	60	165	30,7	RAL 9016	100
<b>382q</b>	<b>382r</b>	40K	150v	K985W	150	60	190	40	RAL 9016	120



<b>382q</b>	<b>382r</b>	40K	125v	K235	125	60	165	30,7	RAL 7004	100
<b>382q</b>	<b>382r</b>	40K	150v	K235	150	60	190	40	RAL 7004	120









<b>382q</b>	<b>382r</b>	40K	125v	K985	125	60	165	30,7	RAL 7004	100
<b>382q</b>	<b>382r</b>	40K	150v	K985	150	60	190	40	RAL 7004	120

electrically conductive!







**Innovative locking mechanism**

The castors of the 382 series have a positive wheel lock, not reliant on friction, which engages in the central web of the wheel. This means that the locking action does not depend on tyre condition, because the castor is braked without contact with the running surface of the tyre.









							
<b>382q 382r</b>	40K 125y	K235W	125	60	165	30,7	RAL 9016 100
<b>382q 382r</b>	40K 150y	K235W	150	60	190	40	RAL 9016 120









							
<b>382q 382r</b>	40K 125y	K985W	125	60	165	30,7	RAL 9016 100
<b>382q 382r</b>	40K 150y	K985W	150	60	190	40	RAL 9016 120



							
<b>382q 382r</b>	40K 125y	K235	125	60	165	30,7	RAL 7004 100
<b>382q 382r</b>	40K 150y	K235	150	60	190	40	RAL 7004 120



							
<b>382q 382r</b>	40K 125y	K985	125	60	165	30,7	RAL 7004 100
<b>382q 382r</b>	40K 150y	K985	150	60	190	40	RAL 7004 120

# 399q

Swivel castor with central brake

# 399r

Swivel castor with directional brake



reddot design award winner 2006

### Technical description

- Die-cast aluminium load-bearing housing
- Highly polished plastic cover, optionally in white RAL 9016 or metallic
- Unique design and patented technology
- Precision ball bearings in the fork head
- Suitable for cleaning in disinfection cabins
- Smooth selection function
- Integrated selection mechanism with total locking brake "q" and direction locking brake "r"
- Permanently grease filled in the switch mechanism
- Load capacity 150 kg
- On inquiry with electrically conductive wheel

### Areas of application

- Care beds
- Hospital beds
- Intensive care beds
- Medical appliances
- OP beds
- OP tables

Guideline for finding the correct structure of attachment, sockets for round and square tubes, as well as foot and transmission lever, see on pages 81-83



<b>399q</b>	<b>399r</b>	38K	150v	K2351	150	32	188	42	RAL 9016	150



<b>399q</b>	<b>399r</b>	38K	150v	K985	150	32	188	42	RAL 9016	150



<b>399q</b>	<b>399r</b>	38K	150v	K2351 A	150	32	188	42	metallic	150



<b>399q</b>	<b>399r</b>	38K	150v	K985 A	150	32	188	42	metallic	150

# Accessories for central locking hospital bed castors

	Product	Specification	Article number
	Wall bumper	95 mm	49G
	Snap-on adapter sleeves round	(see adapter measurements on page 83)	
	Snap-on adapter sleeves square	(see adapter measurements on page 83)	
	Foot pedal double	left right	DHL DHR
	Foot pedal double (Plastic)	left right	KDHL - 9010/7011 - 30° or 45° KDHR - 9010/7011 - 30° or 45°
	Foot pedal single	left right	EHL EHR
	Foot pedal single (Plastic)	left right	KEHL - 9010/7011 - 30° or 45° KEHR - 9010/7011 - 30° or 45°
	Transmission lever long		MNL
	Transmission lever short		MNK

# Guideline for ordering designations for hospital bed castors

## Central locking brakes

Hospital beds must be reliable and easy to manoeuvre. Modern hospital beds are therefore equipped with central locking brake mechanisms, which enable time and energy-saving operation.

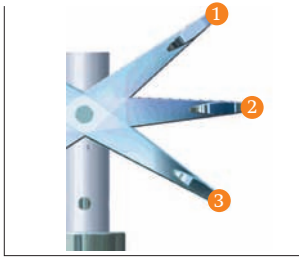

## Directional locking brakes

For setting of straight ahead motion, the use of a directional locking brake integrated in the fixing pin is recommended.

The mechanism allows a central pedal to select the following modes of operation:

- 1: Motion straight ahead (only when equipped with directional locking brake mode)
- 2: Changes of direction: free mobility of all castors
- 3: Full locking of all four castors

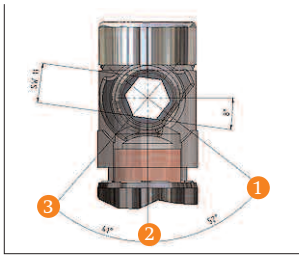

## Fixing pins

Standard-cam (41° und 52°)

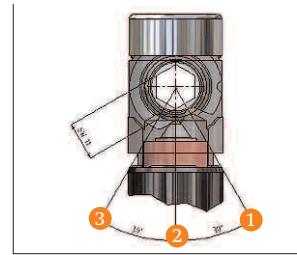

30°-cam

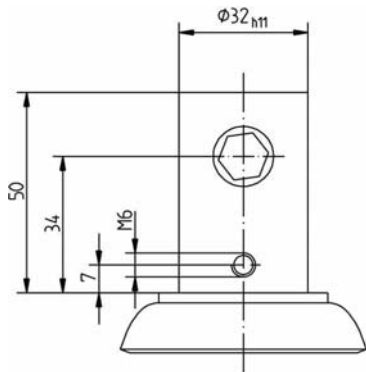

### Fixing Pin 34 mm

- \_ For standard insertion measurement  $\Phi 32$
- \_ Switching shaft variants A/B
- \_ Switching shaft in line or across direction of travel
- \_ Four tapped fixing holes

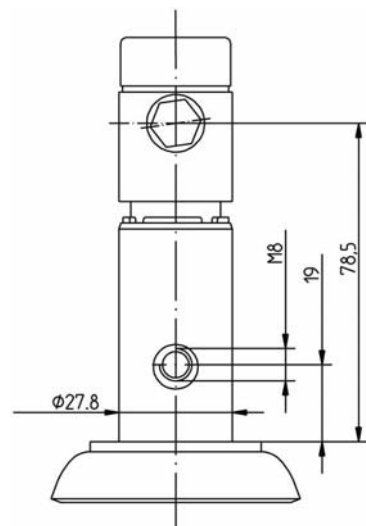

### Fixing Pin 78,5 mm

- \_ For standard insertion measurement  $\Phi 28$
- \_ Switching shaft variants A/B
- \_ Switching shaft in line or across direction of travel
- \_ Four tapped fixing holes
- \_ Snap-on adapter sleeves for different tube measurements available!

The 4-digit order number

How to use the 4-digit order number, e.g.

390q 29K 150v Z 2351

For the products in this chapter further information needs to be added to our reference number (coloured underlays).

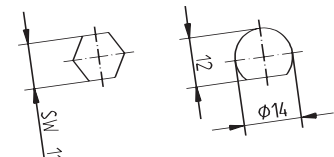
1. Digit:	Distance from the tube seat to middle of the switching bar*	Kind of cam	Switching shaft	A	B
2	x = 78,5 mm	Standard-cam	A		
4	x = 78,5 mm	30°-cam	A		
6	x = 78,5 mm	14-12-cam	B		
8	x = 34 mm	Standard-cam	A		
9	x = 34 mm	30°-cam	A		

\*on request: in 71 mm possible

2. Digit:	Size of the threaded hole*	Distance from the tube seat to the middle of the threaded hole
3	M8	y = 19 mm
8	M6	y = 7 mm

\*on request: M6 / 18 mm and M8 / 18 mm possible

3. Digit:	Position of the bar to the travel direction	Position of the threaded hole to the travel direction
5	across	4-tapped holes
6	along	4-tapped holes

4. Digit:	Adapter measurement		Adapter measurement		
	without	socket (Art. No.)	without	socket (Art. No.)	
0	without				
1	Ø 27,8	9 229 111	5	Ø 28,9	9 229 048
2	Ø 28	9 229 050	6	Ø 33,65	9 229 029
3	Ø 28,2	9 229 025	7	Ø 33,65	9 229 023
4	Ø 28,4	9 229 026	8	Ø 36	HB 22 + 9 229 111



Type I  
Foot pedal  
across direction of travel



Type II  
Foot pedal  
along direction of travel

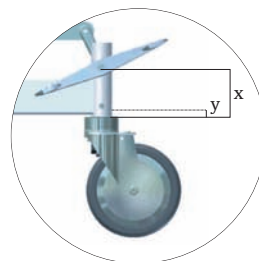

only for pins 71 mm and 78,5 mm

When ordering please indicate additionally to order number:

- Integrated directional lock (directional locking brake): yes/no